

FULL HYDRAULIC DUMP CARRIER

TCR50

Operating Weight:5460kg



TAKEUCHI

TAKEUCHI ... Leading the Way in Dump C

Skip



Operator safety and comfort



- ROPS/FOPS structure ensures operator safety.
- Isolation mountings reduce noise and vibration levels, ensuring operator comfort and productivity.
- Adjustable suspension seat provides maximum comfort and low fatigue.

Traveling



- Two speed travel range, selected by a button on the left hand joystick, allows the TCR50 to travel at high speed on good site conditions, whilst retaining tractive effort for arduous terrain.
- Fail-safe spring operated, hydraulic release, track brakes ensure safe and reliable braking.
- Long-life heavy-duty taper roller bearing track rollers.

Easy of operation

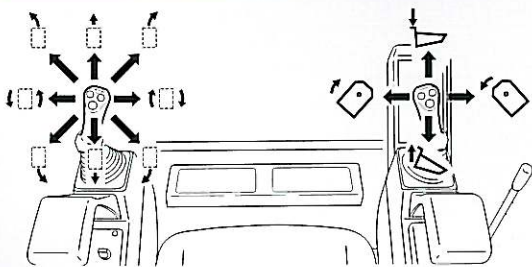

- Twin single lever joystick servo controls for light, precise operation. Left hand lever controls travel speed, direction and steering. Right hand lever controls dump and slew operations.
- Variable displacement hydraulic pump continuously monitors power demand, and automatically adjusts flow and pressure to suit.



Safe

- Safety lockout lever disables travel and loading pallet functions, ensuring safe entry and exit from the cab.

Carrier

Environmental concern

- Skip can be hydraulically rotated through 90 deg. both right and left to precisely position the discharge point.
- Automatic indicator light shows when skip is located in the central position.
- Fail-safe spring operated, hydraulic release, slew brake ensures safe and reliable slew braking.

- Takeuchi's environmental responsibility required fitting the latest design engine, designed to meet the most stringent worldwide exhaust emission standards, and offering significantly reduced noise levels for urban



Serviceability

- Routine engine and hydraulic maintenance is easily achieved, with lots of space available on the carrier upperstructure.
- Skip cylinder (rod and head sides) and pivot pins can be greased without the need to first empty the skip.
- Emergency engine shutdown system prevents engine damage in the event of either engine oil or cooling water loss.
- Audible and visual warning indicates hydraulic filter replacement requirement.



- Careful design has ensured excellent all-round driver visibility from the cab.

TCR50

● Operating Range : mm

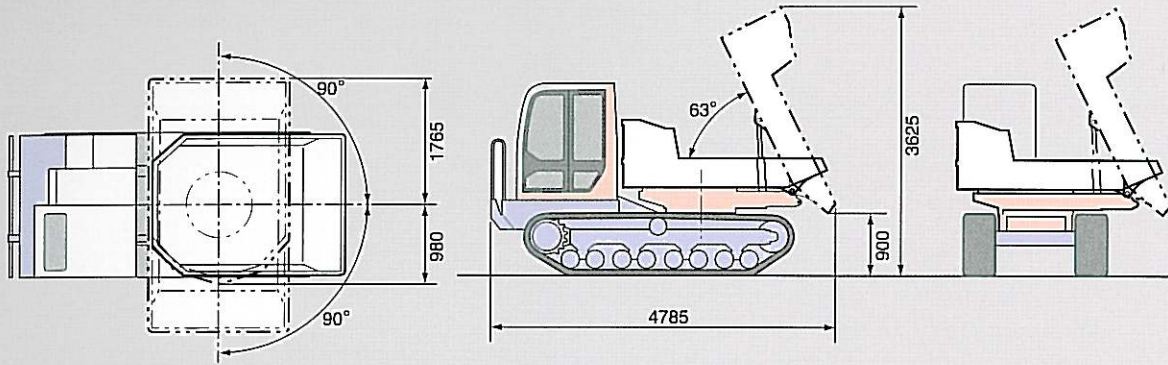

● Machine Dimensions : mm

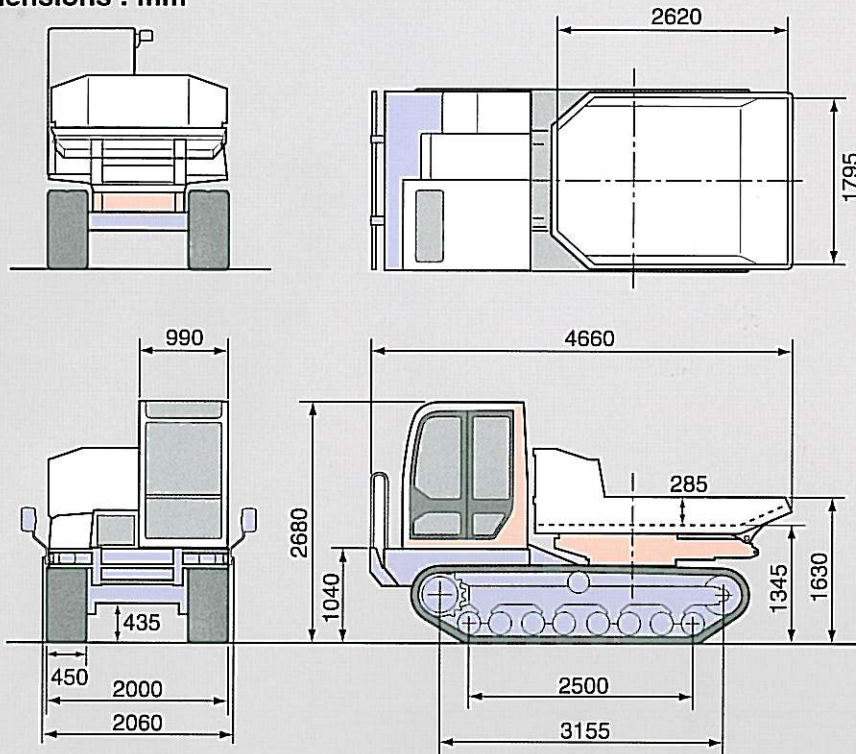

● SPECIFICATIONS TCR 50

Operating Weight	kg	5,460	Skip dimension		P3 MPa	20.6
Skip capa	m ³	2.055	Length	mm	kg/cm ²	210
Engine			Width	mm	Rated flow rate P1,P2	l / min
Model		4TNV106	Max. depth	mm	P3	l / min
Output	kW	67.7	Loading pallet floor height	mm	Traveling speed	km / h
Output	PS	92	Loading pallet flap height	mm	Traction force	kN
Rated rev	min ⁻¹	2500	Max. height when dumping	mm		kg
No. of Cylinder		4	Min. height when dumping	mm	Ground pressure No load	kPa
Displacement	ml	4412	Max. dumping load	kg	Full load	kPa
Max. torque	Nm	292	Dumping angle	deg	Shoe width	mm
Dimention			Dumping speed up	sec	Ground contact length	mm
Overall length	mm	4660	Dumping speed down	sec	Gradeability	deg
Overall width	mm	2060	Slewing speed (180°)	sec	Carrier roller	
Overall heigth	mm	2680	Max. allowable slew angle	deg	Track rollers	
Performance			Hydraulic system		No. of teeth for sprocket	
Max. payload	Kg	3700	setting pressure P1, P2	MPa	Ground clearance	mm
				kg/cm ²		



SIGNUM stavební stroje s.r.o.

Vejprnická 28, 318 00 Plzeň,

mob. +420 733/510 117; 603/225 184; 733/510 107, tel./fax: +420 377 431 898;

Pobočky: *Liberec: 734/311 905; 739/00 9891 *Litomyšl: 602/413 126

*Jeseník: 603/236 160

signum@signum-plzen.cz;

www.signum-stroje.cz

SIGNUM[®]
stavební stroje s.r.o.